



Sound Transmission through Triple Panel Walls - Low Frequency Model

Keith Ballagh

Marshall Day Acoustics Ltd, PO Box 5811, Wellesley St, Auckland 1141

This paper was previously presented at the 21st Biennial ASNZ Conference, Wellington, NZ

Abstract

Triple panel walls are used in many situations but there are few readily available methods for predicting their performance. A common example of a triple panel wall is a masonry wall with light weight plasterboard linings on each side. Such walls can have significant transmission at low frequencies. This paper will describe a lumped parameter model for predicting the low frequency performance of such walls.

INTRODUCTION

Sound insulation between rooms or spaces is often very important, and methods of achieving good performance are well known [1]. However, construction methods and materials continue to evolve, and there is a continuing interest in improving constructions, to make them lighter, cheaper, easier to build and more compact.

It is well known that there is a limit to the sound insulation that can be achieved with a single panel, most single panels obey the mass law, and at practical panel sizes of say, 500 kg/m^2 (200mm concrete) the sound insulation is around STC/R_w 55 - 60 dB.

A major improvement can be achieved by using double panel constructions with an air-gap between, even with relatively light panels, performance of up to STC 65+ can be achieved for construction masses of about 50 kg/m^2 .

If double panels confer such an advantage might it be that triple panel constructions (3 panels separated by 2 air-gaps) would be even better. Some examples of triple panel constructions that are already used in practice include masonry walls with plasterboard linings fixed over battens on each side, or triple glazing used in very cold climates where 3 panes of glass are used with 2 air-gaps, to maximise the thermal insulation.

There are also some examples of triple panel plasterboard walls intended for inter-tenancy use. However, on the whole triple panel walls have not seemed to provide a significant improvement over double panel walls.

Nonetheless, triple panel constructions continue to be used, particularly now in New Zealand after the leaky buildings fiasco has led to the use of ventilated cavities on external façades.

There have been unfortunately no reliable acoustical engineering tools for predicting the performance of triple panel constructions.

This paper will describe the development of methods for predicting the low frequency performance of triple panel walls. Note that it is often the low frequency performance of such walls that determine their overall effectiveness.

ACOUSTIC MODELLING OF TRIPLE PANELS

For modelling double panel walls it has been found satisfactory to divide the frequency region into a low frequency region where a lumped parameter model is satisfactory, a mid frequency region where wave motion in the air cavity is important, and a high frequency region where structural coupling between panels is important [2]. A similar approach has been taken for triple panel walls [3]. This paper will describe the low frequency model.

At low frequencies, where sound waves have very large wavelengths, it is found that it is the bulk properties of materials such as their mass that are most significant. The components in a wall can be regarded as masses or springs coupled together. This is the classical lumped parameter model. Panels are described by their mass per unit area (surface mass) and air-gaps are modelled as springs. In its simplest form a triple panel wall would be represented by 3 masses connected by 2 springs (Figure. 1).

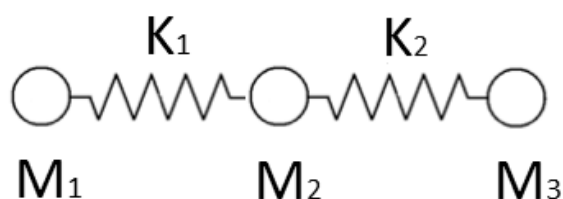

Figure 1. Lumped parameter model of triple panel wall.

Another way of representing such a model is to use electro-acoustic analogs and convert the lumped parameter model into an equivalent electrical circuit, in which masses are replaced by inductances, springs are replaced by capacitors, and damping by resistors. In this view currents represent acoustic velocities, and voltages represent acoustic pressures. The use of electrical equivalent circuits is a well established tool, and allows relative simple solution of the behaviour of the elements in the model, using the impedances of the elements and standard circuit rules

MARSHALL DAY

Acoustics

Consultants in Architectural & Environmental Acoustics



Auckland - Christchurch - New Plymouth - Wellington - Adelaide - Melbourne - Sydney - Guangzhou - Dublin

www.marshallday.com

NEW Echopanel Mura

An innovative acoustic wall covering that is design driven, cost effective and easy to install

- Contains 60% of post-consumer recycled PET
- 1.9mm thick, 1200mm wide and packed in convenient 25m rolls
- NRC of 0.1 when directly applied to a substrate
- 2 plain colours and 11 printed colour options
- Invisible seams when double cut, providing a smooth and continuous installation look



For more information or sales enquiries:

0800 45 4000
www.forman.co.nz

to be able to write out the transfer functions between points in the circuit [4].

The equivalent electrical circuit for a triple panel construction is shown in Figure 2 below. In this resistances have been added to account for damping in the system.

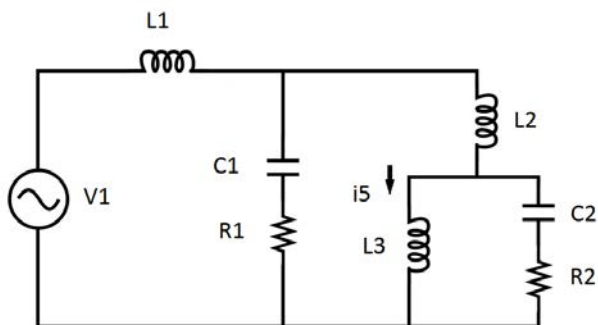

Figure 2. Electrical analogue of triple panel wall.

For the case of sound insulation of a structure (consisting of one or many panels) the transfer function of interest is the ratio of the incident sound pressure (represented by voltage V_1 in the equivalent circuit of Figure 2), to the velocity of the radiating panel (represented by current i_5 in the inductor L_3 in the equivalent circuit).

Now Rindel [5] (after some substitution) gives the transmission loss as:

$$R = 10 \text{ Log} \left(\frac{\langle p_s^2 \rangle}{4(\rho c)^2 \langle v_r^2 \rangle} \right) \quad (1)$$

and it can be seen that it is ratio of incident pressure $\langle p_s \rangle$ to velocity $\langle v_r \rangle$ of the radiating panel that is important. The incident pressure is represented by the applied voltage V_1 in the equivalent circuit, and the velocity of the third panel by i_5 , the current through the inductor L_3 .

By using standard Fourier transform methods the transfer function can also be derived.

This lumped parameter model is reasonably valid up to a frequency for which the larger air cavity is equal to about $1/6^{\text{th}}$ of a wavelength of the incident sound. For instance, for a cavity of 100mm the highest frequency for which the lumped parameter model should be used is 550 Hz. This still covers a very useful and important part of the frequency range.

Once the transfer function has been determined it is a simple matter to use software to solve for the sound transmission loss of a triple panel system.

As a simple illustration the predicted transmission loss of a triple panel wall is shown in Figure 3. The wall consists of a 13mm thick plasterboard, 90mm air-gap, 13mm plasterboard, 10mm air-gap, and a further sheet of 13mm plasterboard. The transfer function predicts resonant frequencies of 74 Hz and 263 Hz. The predicted sound transmission loss exhibits dips in performance in the 80 and 250 Hz $1/3^{\text{rd}}$ octave bands, coinciding with the two resonant frequencies of the system. Note that above the

second resonant frequency the transmission loss curve rises sharply with frequency (30 dB/octave) as you would expect from an ideal 3rd order system. In practice other effects such as wave motion in the cavities, structural connections, bending waves in the panels, will limit the mid and high frequency performance of typical walls.

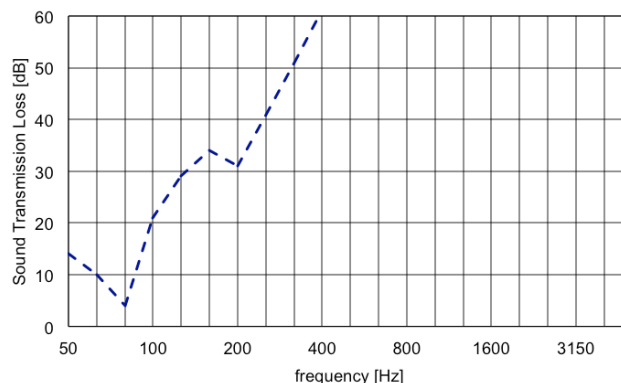

Figure 3. Sound Transmission Loss of simple triple panel construction (gypsum board/airgap/gypsum board/airgap/gypsum board).

EXPERIMENTAL VERIFICATION

We have a relatively sparse set of suitable laboratory test results of triple panel walls that we can use to compare against the model. NRC in Canada has carried out a set of tests on a concrete block wall, with some different linings and these have been used to test the model [6]. In Figure 4 we compare the model to the laboratory test for a 190mm thick solid filled concrete block wall (260 kg/m²), with 16mm gypsum plasterboard each side, fixed over 38mm thick timber battens, with a 38mm thick fibreglass blanket in the stud cavity.

It can be seen that the model predicts the transmission loss relatively well up to about 250 Hz, above which frequency structural transmission via the timber battens begins to be more significant. In Figure 5 a similar construction is compared, except the 38mm timber battens have been replaced with 50 mm steel Z channels, and in Figure 6 the construction uses 75mm steel Z channels. In the three constructions described above the cavities are filled with a fibreglass blanket.

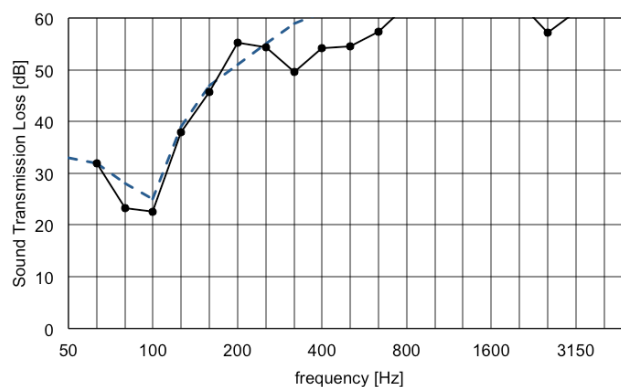

Figure 4. Sound Transmission Loss of 190 mm concrete block wall with 38mm timber strapping and 16mm plasterboard both sides.

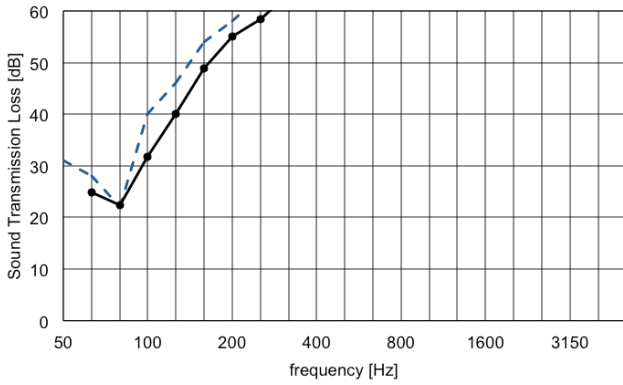

Figure 5. Sound Transmission Loss of 190mm concrete block wall with 50mm steel channels and 16mm plasterboard both sides.

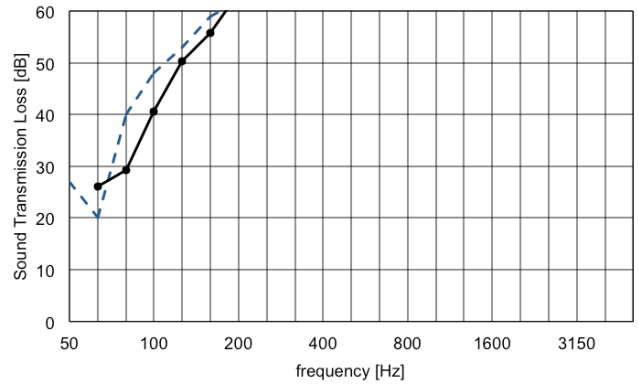

Figure 7. Sound Transmission Loss of Timber stud wall with 14.5mm gypsum board linings and additional layer fixed over resilient channels.

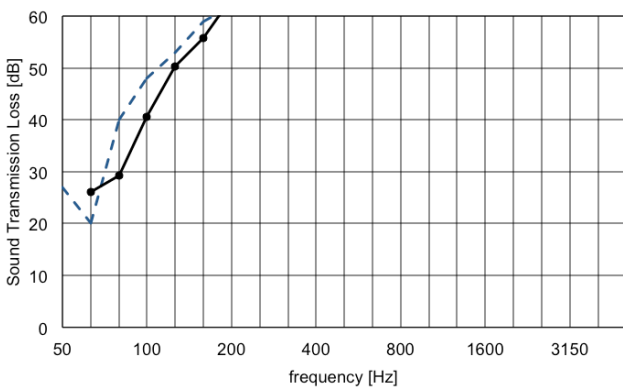

Figure 6. Sound Transmission Loss of 190mm concrete block wall with 75mm steel channels and 16mm plasterboard both sides.

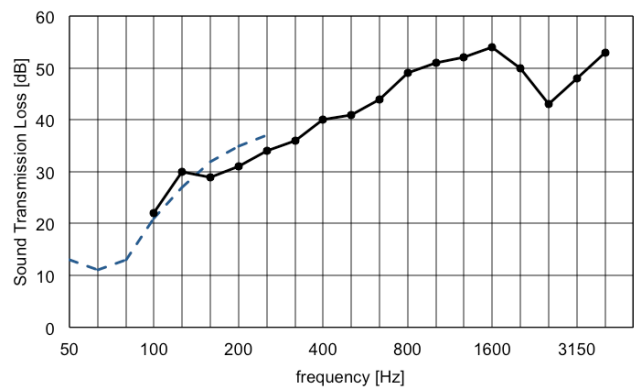

Figure 8. Comparison of Sound Transmission Loss of equal mass and thickness constructions. (blue line ~ double panel, black line ~ triple panel).



NOISE CONTROL SERVICES
ACOUSTIC PRODUCTS AND DESIGN

is now...



NCS Acoustics
DESIGN · MANUFACTURE · INSTALL

Although known in the industry as leaders in the design, manufacture and installation of acoustic solutions, we still get many calls asking us to *"Come and turn the neighbours stereo down, for \$@#% sake!"* Unfortunately we can't help people with their inconsiderate neighbours. To stop this confusion the company has become 'NCS Acoustics Ltd'.

We moved into a purpose built factory in Takanini in 2007, and have a new postal address. Due to the new company name, our email address and website also need updating. Please ensure our details are correct in your database.

P +64 9 269 0001
 E info@ncsacoustics.co.nz
 NCS Acoustics Ltd, PO Box 202 285, Southgate 2246
 112 Takanini School Road, Takanini, Auckland, New Zealand
 www.ncsacoustics.co.nz

"Sorry - we don't turn down stereos!"



When you need a little peace and quiet, just close the door.



Pacific Door Systems' new 'AD' series single-leaf acoustic doorsets let you mix and match sizes of vision panels, frame types and door surfaces while still achieving acceptable STC/Rw ratings.

These flush-panel doors, hung in timber or steel frames, are the result of 15 months of intensive testing and development in our own in-house acoustic laboratory—a two-chamber facility designed by a leading Acoustic Engineering Consultancy to test full size products in accordance with ISO 140-1 and 3, using Norsonic microphones and sound level meter, and Norbuild software.

Each door in our new range is individually certified to meet both international standards and your specifications.

Lightweight AD100. Interior doorset for general use, offers STC/Rw 35. Priced to compete with solid core doors and proprietary seals having a lesser rating.

Medium-Weight AD200. Interior doorset offering up to STC/Rw 36–38, which can also be incorporated into the PDS 'hospital series' or become a commercial-quality exterior unit rated to STC/Rw 40.

Medium-Weight AD300. Robust interior doorset achieving 40 STC/Rw. Can be incorporated into the PDS 'hospital series.' Bridges the commercial cost gap between AD200 and AD400.

Medium-Weight AD400. The 'Flagship' of our range. Robust interior doorset offering STC/Rw 43 for any environment.

In late 2012 we'll release 'AD' series pairs, a new fire/acoustic single and pair unit, and a 50 plus STC/Rw sound attenuation unit.

For full specifications of our range of acoustic doors and other products, visit www.pacificdoors.co.nz

17 Meachen Street, Seaview, Lower Hutt.
Tel: (04) 568 6109; Fax: (04) 568 8531; Email: sales@pacificdoors.co.nz
For specifications, visit www.pacificdoors.co.nz



MMA 12/3

The agreement between the sound transmission loss predicted by the lumped parameter model and the measurements is reasonably good, the dip in transmission loss is predicted with reasonable accuracy. Note that the depth of the dip at the resonance frequencies is governed by the amount of damping. A value of resistance of 2,000 Pa s/m has been chosen for each example as the best overall fit to the experimental data.

In Figure 7 a comparison between prediction and theory is shown for a plasterboard partition consisting of 14.5mm gypsum board each side of a 90mm timber stud, with an additional layer of 14.5mm gypsum board attached via a resilient rail (thus creating a 13mm airgap).

This is an old test (1988) before laboratory testing was extended down to 50 Hz, so only results down to 100 Hz are available. There is reasonable agreement over the range available.

DISCUSSION

Resonance Frequencies

The behaviour of a triple panel system is influenced by two resonant frequencies. These resonant frequencies are not simply the resonant frequencies of each side of the construction. As an example consider a system consisting of a layer of 13mm plasterboard, a 100mm air cavity, and another layer of 13mm plasterboard.

The mass-air-mass resonance frequency is 64 Hz. If we now add another air cavity of 100mm and another sheet of 13mm plasterboard there are now two resonant frequencies, one of 53 Hz and one of 92 Hz. Thus, the modes of vibration can only be determined by taking the interaction of all components of the system.

Even with a heavy panel in the middle, as for instance if we substitute 150mm concrete as the middle panel, the resonance frequency of one layer of plasterboard and the concrete with 100mm air-gap is 46 Hz, but with the same lining on the other side of the concrete the resonant frequencies become 53 and 55 Hz.

Comparison of Triple and Double Panels

It is interesting to compare a double panel and triple panel system where the overall width and mass of the system is constrained. Take a wall which has an overall width of 100mm and consists either of 3 sheets of 13mm plasterboard separated by 2 air cavities of 30mm, or of 2 sheets of 20mm plasterboard (the same mass as a triple panel system) separated by 60mm. Both systems have the same mass, and same overall width.

The results are shown in Figure 8 where it can be seen that although the triple panel system has superior performance at higher frequencies, its performance at low frequencies is markedly inferior. The triple panel system has resonance frequencies of 93 Hz and 161 Hz, and a sound reduction of 12 dB at 100 Hz. The double panel system has a resonant frequency of 63 Hz, and a sound reduction of 22 dB at 100 Hz.

For typical lightweight building components and structures this is likely to be true for most designs. Therefore in general it is best to maximise the main airgap and maximise the mass of the outer skins for the design that is most efficient in terms of overall mass and compactness.

CONCLUSIONS

A simple lumped parameter model of a triple panel wall construction has been developed. The model consists of three masses (the panels) connected by two springs (the air cavities). The model predicts two resonant frequencies, which will produce two dips in the sound transmission loss. Comparison with available experimental data shows good agreement at low frequencies between predicted and measured performance for a limited range of constructions.

ACKNOWLEDGMENTS

I would like to gratefully acknowledge Harry Trethowen, formerly of BRANZ, for drawing my attention to the work of Ben Sharp and thus stimulating my enduring interest in the prediction of sound transmission.

REFERENCES

- [1] GIB® Noise Control Systems Book March 2006. Winstone Wallboards Ltd.
- [2] B. H. Sharp, "Prediction Methods for the Sound Transmission of Building Elements", Noise Control Engineering Vol 11, 1978.
- [3] Marshall Day Acoustics, INSUL V7.0 "Sound Insulation Prediction Software" 2012.
- [4] J. Blauert And N. Xiang, "Acoustics For Engineers", Springer-Verlag Berlin 2008 .
- [4] J.H. Rindel, "Sound Radiation from Building Structures and Acoustical Properties of Thick Plates". COMETT-SAVOIR Course, CSTB, Grenoble, March 1995.
- [5] A.C.C Warnock, "Sound Transmission Through Concrete Block Walls with Attached Drywall", J. Acoust. Soc. Am. 90 (3), September 1991. ¶

ACOUSTICS 2013
VICTOR HARBOR
Science,
Technology
and Amenity
VICTOR HARBOR, SOUTH AUSTRALIA
NOVEMBER 17-20, 2013