



¹ P Kirsty Tanner, Neil Mackenzie, Richard Jones and Yong-Keat Lee
¹ Aurecon Pty Ltd, Australia

Abstract

Façade designs are becoming increasingly complex, resulting in an increased occurrence of a façade generating wind-induced noise which can be a nuisance for sensitive receivers. Despite this, wind-induced noise is often overlooked in the design of a façade. This paper highlights typical wind-induced noise mechanisms and typical methods used to assess and quantify the potential for a façade to generate noise. A novel technique is presented which was developed to assess the potential of a façade to generate noise. Application of this technique to a case study is discussed for the Adelaide Medical and Nursing Schools (AMNS) project, a new campus facility at the western end of North Terrace in Adelaide's CBD.

Originally published in the Proceedings of ACOUSTICS 2016, Brisbane, Australia

1. Introduction

Wind-induced noise is often overlooked for building design. Wind noise can be generated by wind flowing over façade elements or through gaps within buildings. Noise generated from wind impacting façade elements, especially at higher wind speeds has received increased attention in recent years. The most notable example is Europe's tallest residential building in Manchester, England, known as "Beetham Tower", which received widespread publicity when completed, refer to Figure 1, as reported by Leeming (2006). Baker (2015) has recently reported that work to reduce or eradicate the noise took place in 2007 with foam pads installed, aluminium nosing in 2007 and further undisclosed work completed in February 2010. Attempts to eradicate the noise permanently have been unsuccessful.

Ploemen et al. (2011) provides evidence of two tall buildings, part of the Hague in the Netherlands, which became notorious for noise generated at wind speeds of around 12-15 m/s, with steel grids being claimed to be the noise source. Other recent and local examples include Aeolian noise generated by the finned balustrade of freeway pedestrian overpasses installed at 6 locations along the 40 km Eastlink project in Melbourne, Australia (Mitchell et al., 2010). Noise levels at nearby residential properties were reported to be 40 dB greater than the background (or ambient) noise level.

There is a strong overlap between acoustic and wind engineering, with recent developments in the assessment of noise from wind farms instigating improved understanding of aerodynamic sound concepts (as well as an understanding of meteorological conditions and models usually associated with air quality and dispersion analysis). The study of aerodynamic sound began with noise from jets (Lighthill, 1952 & 1954), and was developed within the domain of aerospace (high mach numbers) and mechanical (low mach numbers) engineering. Lighthill rearranged the Navier-Stokes equations governing fluid flow (conservation of mass, momentum and energy) into a wave equation describing the acoustic field generated by turbulence.



Figure 1: Article from The Enquirer – North West, from Leeming (2006)

2. Facade aeroacoustics - Previous work

Rofail and Tonin (2000) first introduced the issue of "wind-noise" in buildings. Full-scale wind tunnel measurements were carried out with flow through an open window/door with recesses in aluminium extrusions as per Figure 2. Results indicated that the wind speed coinciding with the onset of Aeolian tone generation is dependent on gap width, and frequency of the tone is dependent on incident wind speed. The sound pressure level was found to increase with wind speed and, for constant wind speed,

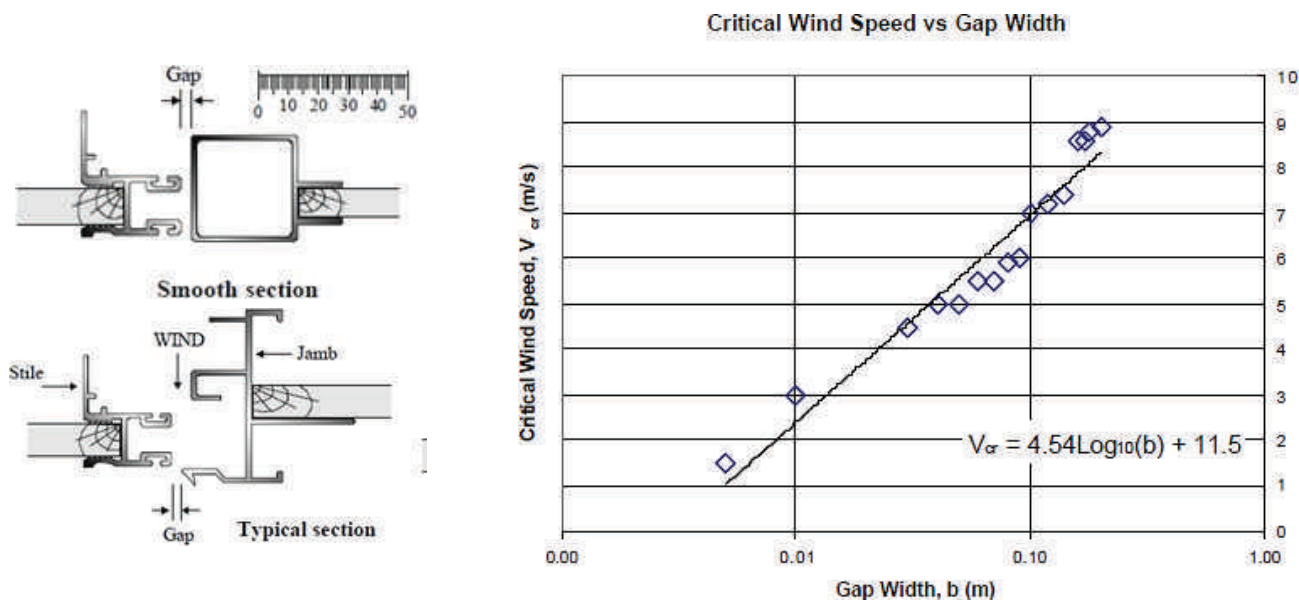

Figure 2: Wind generated noise from accelerated flow across a cavity (Rofail and Tonin, 2000)

decrease with gap width.

Moloney et al. (2010) provided a general discussion of testing and assessment of wind noise around buildings which briefly discussed aerodynamic noise sources (eg. vortex shedding, cavity resonance, structural resonance) and potential issues with building elements (eg. cables, slots, etc.). Various test methods rather than analytical or computational methods were introduced to identify problems with building elements.

Coppa and Paduano (2015) describe a design process to evaluate the potential of wind noise for façade elements using computational fluid dynamics (CFD). CFD modelling demonstrated vortex shedding from sunshade elements by calculating the power spectral density of the time trace of the pressure coefficient. There is some discussion on “lock-in” phenomena or coincidence of

vortex shedding with acoustic resonance, but no definition of the radiated sound power level. Coppa and Paduano also outline the Arup Acoustics guidance notes (Figure 3a) that have “never been fully tested or studied extensively” and have been “too often deemed impractical and unreasonable from an aesthetic and façade engineering standpoint”. Coppa and Paduano’s work also highlighted the importance of flow parallel to the façade.

Fricke (2010) initiated some work on local façade velocity estimates, as shown in Figure 3(b), with local peak (3 second gust) velocities at the roof edge up to 1.7 times the incident peak velocity. Mean and peak wind speeds and multipliers to account for directionality, topography, terrain and the like are well established in building codes such as AS/NZS1170 but are not ordinarily recognised nor understood by acoustic consultants.

Norman Disney & Young

Passionate about acoustics?
We hear you.

www.ndy.com

Parliamentary Select Committee Rooms, Wellington

Auckland	Christchurch	Wellington
t +64 9 307 6596	t +64 3 365 0104	t +64 4 471 0151
e auckland@ndy.com	e christchurch@ndy.com	e wellington@ndy.com

Elements-aperture	Dimension	Comments
Unsealed slots, apertures and exposed elements within façade cladding	>100mm	For exposed elements introduction of vibration damping treatments needed. For cavities and apertures it is recommended to close all openings and apertures to avoid the creation of resonant cavities.
Wires, circular cables, tubular elements or hollow sections	>50mm	If a bigger dimension than 50mm is not possible to be included then provide special damping treatment.
Array elements	>100mm	In case of regular array of elements, smaller dimension of apertures should be avoided or provide special damping.
Constructions	>100mm	Irregular constructions should be used to break-up vortex street formations.

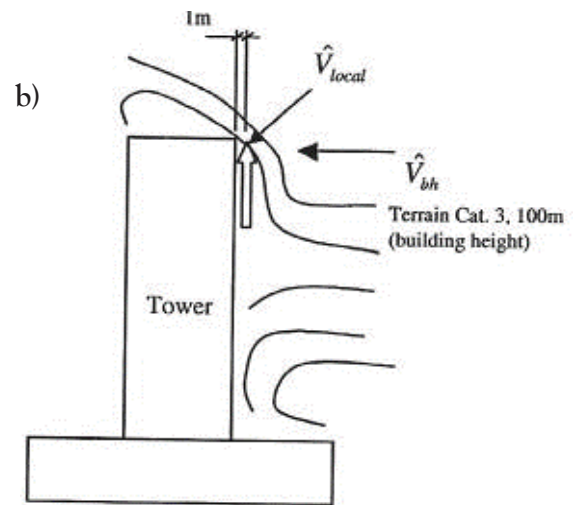

Figure 3: a) Arup Acoustics guidance notes (Coppa and Paduano, 2015); b) Wind velocity across a façade relative to the incident velocity at building height Fricke (2010)

3. Aerodynamic noise sources and aeroacoustics

Noise generated from fluid flow is called aerodynamic sound and is considered within the field of aeroacoustics. Subsonic flow can be classified into three source types: monopole, dipole and quadrupole. A monopole source is produced by pulsating flow or flow which causes pulsations such as flow over a small aperture in a wall, with the flow inducing pulsating motion of air in the aperture. A dipole is produced when flow interacts with surfaces or bodies, such as vortex shedding from airfoils, cables or similar. A quadrupole is formed by Reynolds stresses in a turbulent flow, such as that of a jet or the turbulent boundary layer

over a flat plate. The radiation efficiency of dipoles and quadrupoles is less than that of monopoles due to phase cancellation of pressure pulsations (depicted in Figure 4).

As an example, sound pressure levels measured by Rofail and Tonin (2000) for flow exciting a cavity resonance (refer to Figure 2) is shown in Figure 5 b). Change in sound pressure is consistent with the 4th power of the velocity ratio suggesting the aerodynamic noise source is of monopole type.

Similarly sound pressure levels measured by Akagi et al (1998) for Aeolian tones generated from vortex shedding of power lines are given in Figure 5a), with the change

in sound pressure level with doubling of the wind speed consistent with the 6th power of velocity suggesting the aerodynamic source is of dipole type.

Source type	Radiation characteristic		Directivity pattern	Radiated power is proportional to
	180° phase difference			
a Monopole				$\rho L^2 \frac{U^4}{c}$
b Dipole				$\rho L^2 \frac{U^6}{c^3}$
c Quadrupole				$\rho L^2 \frac{U^8}{c^5}$

Figure 4: Aerodynamic noise source types (Ver and Beranek, 2006)

4. Analytical methods

Analytical methods can be used to estimate wind speeds required to generate noise for typical flow interactions. Semi-empirical approaches can be used to estimate the frequency and intensity of the resulting acoustic field. Some common flow interactions, and mechanisms of wind-induced noise utilising these methods are discussed in the following.

Aerodynamic noise at low wind speeds is usually caused

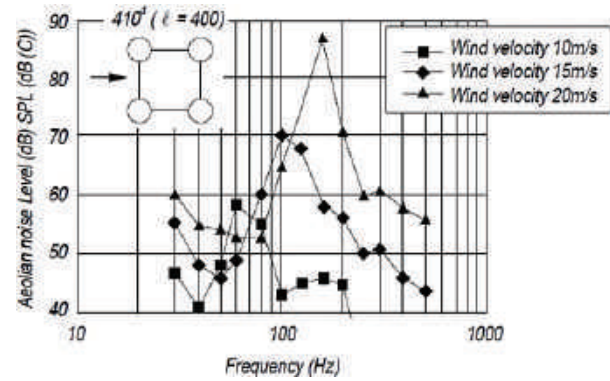
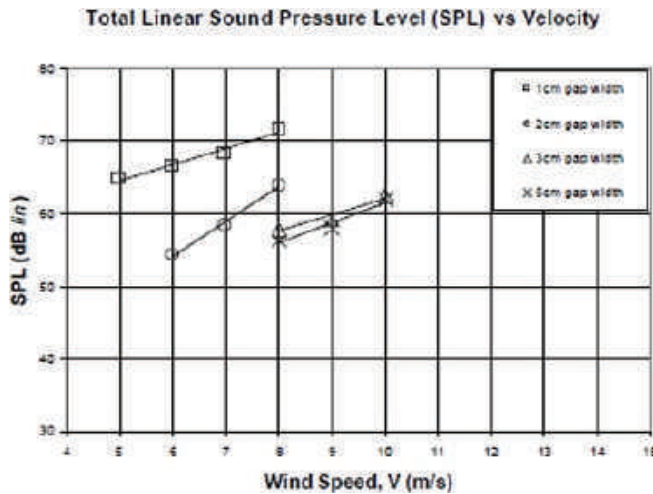

Figure 5: Aeolian noise generated from: a) a 4-bundle conductor (Akagi et al 1998); and, b) excitation of a cavity resonance (Rofail and Tonin, 2000).

by tonal noise (or “*aerodynamic whistle*”) or modulation thereof. Chanaud (1970) provides a summary of tonal noise generation mechanisms which, as shown in Figure 6, can be classified into 3 types:

- Class I:** Hydrodynamic feedback generated by vortex shedding from bluff bodies such as cylinders. Generally well understood method of noise generation, with the frequency of the tone determined from the Strouhal Number, and the intensity based on the Scruton Number. This is similar to the example provided for Akagi et al. (1998), with the theory generally well understood.
- Class II:** Acoustic feedback from sound generated by flow onto a bluff body (eg. Jet impinging an edge, or jet impinging an orifice). Acoustic feedback from vortices induced by the jet impacting on the nearby edge generates a dipole acoustic source which radiates acoustic energy back into the impinging jet, further enhancing the periodic generation of vortices.
- Class III:** Require a resonating or reflecting structure to perpetuate the acoustic feedback, with the frequency of the tone dependent primarily on the resonant modes of the reflecting/resonating geometry. This is characteristic of flow over a cavity with methods presented in Ver and Beranek (2006) of Rossiter’s

formula and the like.

5. Numerical methods or computational aeroacoustics

The rearrangement of the compressible Navier-Stokes equations into the non-homogeneous wave equation is known as Lighthill’s acoustic analogy (Lighthill 1952). The left hand side of this equation represents acoustic propagation while the right hand side contains noise sources produced by all remaining fluid motion. Problem classification depends on the coupling between noise sources and propagation.

One-way coupled aeroacoustic problems occur when fluid dynamic motions induce acoustic waves and there is no significant feedback. This tends to occur in incompressible flows, such as wind around buildings where resonances do not occur. Here the acoustic analogy can be solved in two parts; first the time varying incompressible flow is solved by standard CFD techniques to obtain the aerodynamically generated acoustic source terms, and then a dedicated acoustic solver is used to calculate the acoustic propagation of those sources. Alternatively, two way coupled problems occur when there is significant feedback from the acoustic waves to the fluid dynamics. In these situations the complete aerodynamic and acoustic

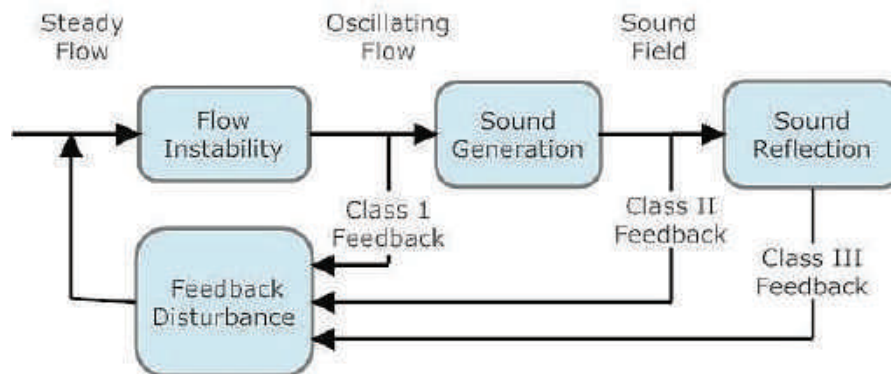

Figure 6: Tonal noise generation methods (Chanaud, 1970)

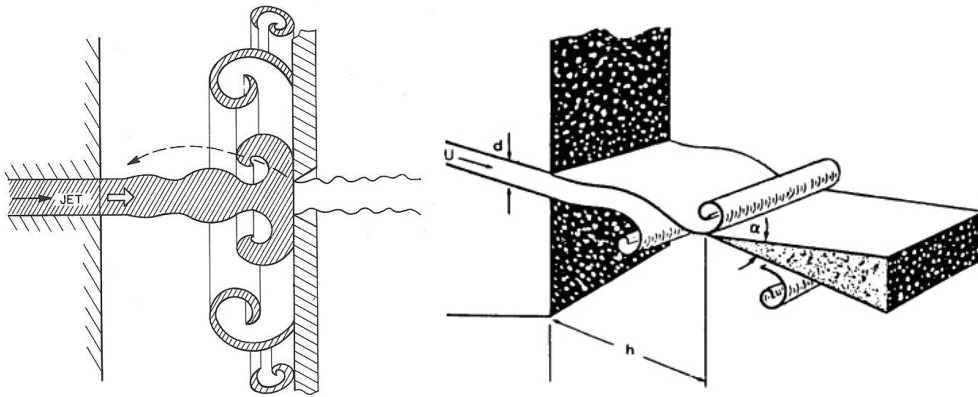

Figure 7: Acoustic feedback resulting from vortex shedding affecting flow within the jet

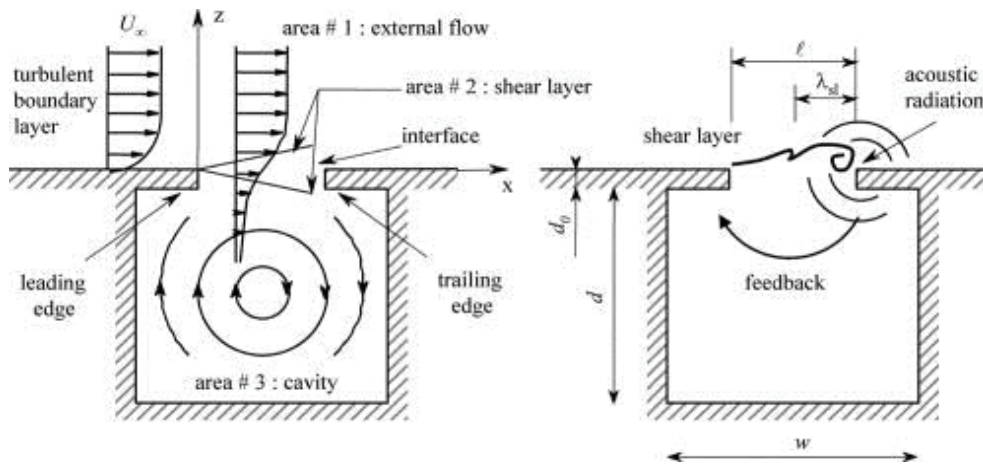

Figure 8: Acoustic feedback due to flow over a cavity perpetuated by acoustic resonance within the cavity

system needs to be solved simultaneously.

For one way coupled problems the time dependent fluid motion must be solved. In general the finite volume method is the primary method for CFD of engineering scale problems. Within this framework the two main categories of analysis are Large Eddy Simulations (LES) and Reynolds Averaged Simulations (RAS). LES is generally an attractive method of calculating aerodynamic noise sources since a majority of energy will be accurately resolved in the larger, resolved eddies. However, the computational resources required for industrial scale applications are still

prohibitively expensive for most practitioners. Reynolds Averaged Simulations dramatically lower the required computational resources compared to LES, often at the expense of accuracy. If a steady RAS solution is calculated, then the time or frequency record of noise sources must be artificially synthesised by other means (e.g. stochastic noise generation). With aerodynamically generated source terms obtained by one of the CFD methods listed above, a one-way coupled problem requires calculation of acoustic propagation by either integral or differential methods. Integral methods include general solutions to Lighthill's acoustic analogy such as the Kirchoff integral or Ffowcs-Williams and Hawkins equation. These methods only include limited effects of the fluid shear layer on the propagating

acoustic waves, if at all. Differential acoustic methods such as Linearised Euler Equations (LEE) or Acoustic Perturbation Equations (APE) are, however, capable of including such effects. An alternative to traditional finite volume CFD is a simplified method known as the Lattice Boltzman Method (LBM). It uses a microscopic approach applying conservation of mass, momentum and energy to particles moving in a lattice structure. As demonstrated by de Jong (2008), LBM is able to accurately predict the frequency and intensity of sound generated by hydrodynamic and acoustic feedback mechanisms, as well as acoustic resonance. This is a promising approach for building aeroacoustics where resonance is significant.

acoustic waves, if at all. Differential acoustic methods such as Linearised Euler Equations (LEE) or Acoustic Perturbation Equations (APE) are, however, capable of including such effects.

6. Wind tunnel test methods

It has become customary to test full-scale façades or elements as shown below in Figure 10 (Ploemen et al., 2011) to assess their potential for wind generated noise (or assess the cause of the noise post construction). Ploemen noted that two types of tones were measured, type I which increased in frequency with increasing wind speed, and type II which

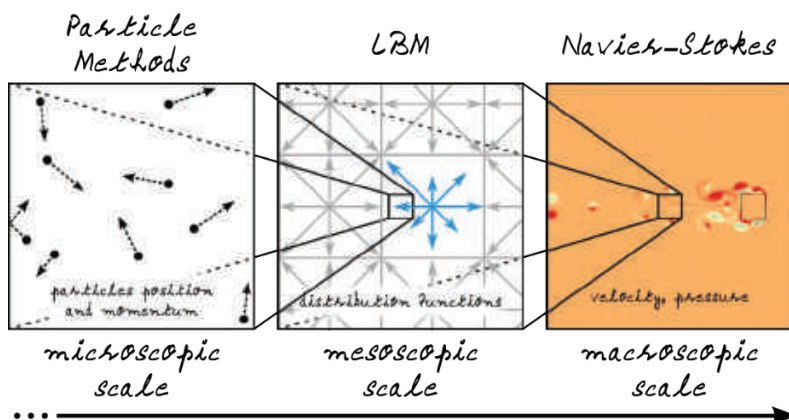

Figure 9: Comparison of computational methods

The new GIB Noise Control® Systems literature is here

Featuring new intertenancy
central barrier wall systems
and floor/ceiling systems.

- Tried and trusted – with over 400 hours of testing and development
- Over 60 noise control systems
- NEW: Five steel-frame central barrier systems and four new lightweight intertenancy floor/ceiling systems

Download or order your copy today at gib.co.nz
or contact us at 0800 100 442.



had a constant frequency but increased intensity with wind speed. Wind tunnel testing could not define the mechanism behind these types of tones. The acoustic response of the façade element for a range of wind speeds is shown in Figure 10.

By exposing a scale model of a façade, or an element of the façade, to scaled atmospheric wind conditions wind tunnel testing can be used to predict wind effects on the full-scale façade. Similarity laws allow results measured for a scale prototype to be applied to the full-scale model, reducing number of tests required and cost involved. Similarity utilises non-dimensional analysis which reduces the number of variables investigated. Similarity can be described as geometric, kinematic and dynamic similarity whereby the ratio of model to prototype dimensions, velocities and accelerations, and applied forces, respectively, are equal.

Kinematic and dynamic similarity is commonly achieved by Reynold's number equivalence, although other non-dimensional parameters may be suitable. Reynolds number equivalence (for example) requires a prototype $1/10^{\text{th}}$ of the actual size (tested in the same fluid as that to which the model will be exposed) to be exposed to a flow speed ten times faster to produce similar flow characteristics. Achieving this similarity requirement can be an issue depending on the wind tunnel's upper-limit wind speed.

Although small-scale testing can have time and cost benefits, full-scale testing may be preferred if small-scale measurements cannot be applied at full-scale appropriately, an appropriate wind tunnel is not available, or the cost and time benefits of small-scale are not seen to be worthwhile pursuing. When considering full-scale testing it is important to consider blockage effects in the wind tunnel test section. The real-life structure is essentially exposed to wind in an infinite space, whereas the test model is tested in a confined space. Distortion of the boundary layer flow occurs if the area of the test

model projected onto a plane normal to the flow direction (blockage area) is significant compared to this area of the test section (Choi and Kwon, 1998).

7. Case studies

This section describes a case study for aeroacoustic assessment of a façade. The building of interest is the University of Adelaide's new Medical and Nursing School building located on North Terrace, along-side the main rail corridor into Adelaide. This building is shown in Figure 11, with a relatively complex façade. A meteorological assessment was completed to establish the frequency of occurrence of wind speeds in each wind direction. CFD was used to assess wind flow across the façade as shown in Figure 12. Semi-analytical methods were used to assess the potential for wind generated noise, which were later tested inexpensively in a factory rig with a quiet fan and spun nozzle, shown in Figure 12. The general methodology utilised in this assessment is described below.

To understand whether aeroacoustics is likely to be an issue for a particular façade or element it is important to understand the local climate, and more importantly, local wind conditions. Although it may be anticipated that a building element will be an aeroacoustic source, there is potential that the frequency of occurrence is so small such that the noise is of little concern. Thus it is important to understand the site's prevailing wind directions and distribution of wind speeds in these directions. At least one year of hourly observations from the nearest Bureau of Meteorology (BoM) site is typically analysed, and a wind rose generated (see Figure 13), graphically depicting local wind speeds and wind directions relevant to the site.

Upon establishing typical on-site wind conditions CFD modelling can be completed to simulate these conditions, including local effects such as surrounding structures and complex terrain. Wind speeds at locations on or near the building's façade can be estimated from such an assessment (see Figure 12). CFD modelling requires creation of a

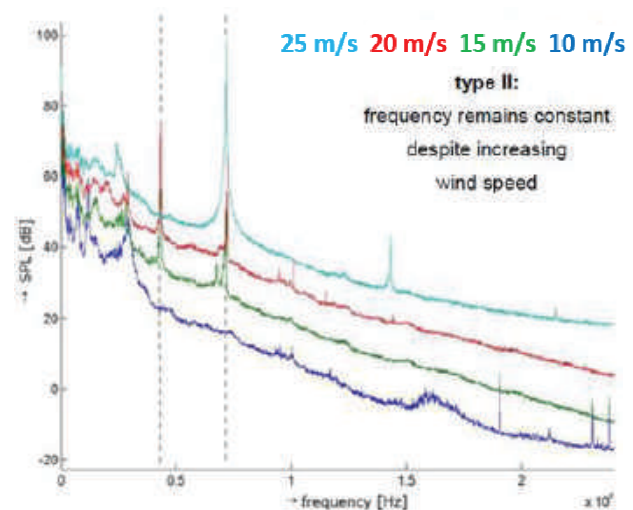

Figure 10: Wind tunnel test setup of façade element (left) and noise levels measured from test (right)

EST. 1966



POTTER
INTERIOR SYSTEMS

ACOUSTIC WALL COVERINGS

SUSPENDED CEILING GRID + PANELS

COMMERCIAL + INDUSTRIAL INSULATION

WHITEBOARDS + DISPLAY SYSTEMS

ALUMINIUM PARTITIONS

PASSIVE FIRE SYSTEMS

Potter Interior Systems provide quality acoustic solutions for a wide range of environments, applications and spaces.



0800 POTTERS | www.potters.co.nz | info@potters.co.nz | Auckland, Hamilton, Wellington + Christchurch



Figure 11: University of Adelaide's new Medical & Nursing School – LEFT: Artistic Impression; RIGHT: As Built

three-dimensional massing model of the building of interest, and of nearby surrounds. Surrounding buildings, especially those removed from the building of interest, can be modelled to a lower level of detail.

Another input into the model is correct representation of turbulent and shear effects in the approach flow arising from positioning and heights of upstream structures. Turbulence and shear effects are replicated by creating and using a boundary layer profile which compensates for inclusion of only limited surrounds. The boundary layer profile specifies flow properties of speed and turbulence at various heights above ground level to ensure flow properties change appropriately with increased height above-ground. This profile is specified at the inlet faces of the model's domain.

Façade shading elements, particularly at the junction between glass panels, were identified as potentially causing wind-induced noise issues. Smaller structural elements (< 50 mm) can generate noise at low-to-medium wind speeds, whereas larger elements (dimensions of up to or greater than 200 mm) require much higher wind speeds (in excess of 20 m/s) to generate noise. Thus, it is often the smaller façade elements which have the potential to create the most frequent noise annoyance.

To study the potential of the façade shading element to generate wind-induced noise, the design (spacing and width) of the elements was carefully reviewed and compared to existing studies detailing wind-induced noise for similar element geometry. Semi-analytical methods published by Ver and Beranek (2006) and others were used to estimate the likely frequency and intensity of tonal noise. Modifications to the design were recommended based on this analysis.

To confirm the results from the analytical assessment, prototype testing was required. Rather than test in a large wind tunnel, a quiet jet fan was used for prototype

testing of a sunshade element, shown in Figure 12. The fan type, nozzle size and silencer were carefully selected such that the required air velocity was achieved, whilst maintaining a relatively low background noise. A variable speed drive was connected to the fan motor to vary the airflow velocity, and a hot-wire anemometer and array of microphones (positioned outside the flow) were used to record the results. Before conducting measurements, all constant noise sources in the room (e.g. air conditioner) were turned off. During measurements, the speed of the jet fan was set to simulate the expected wind conditions across the façade. Sound pressure levels and airflow velocity were recorded concurrently. The test was repeated for various angles of flow incident on the test element, to detect dependence of tone on wind direction.

8. Conclusions

This paper has highlighted the increasingly common, and typically overlooked, issue of wind-induced noise impacts for façade design. Work which has been completed previously to understand wind-induced noise mechanisms, and methods commonly used to quantify this noise for a particular façade design, have been described. Finally, a case study was discussed to demonstrate a novel technique of façade aeroacoustic assessment. Unlike previous assessments, this technique combines outputs from multiple assessment types to assess the potential of a façade to generate wind-induced noise, as well as the occurrence, frequency and intensity of this noise. An issue for further consideration is the subjective response of occupants to wind noise on a daily, weekly, monthly basis to establish appropriate criteria.

9. Acknowledgements

We would like to acknowledge the support from the University of Adelaide's Property Division and Lend

NEW

PULSE REFLEX™ ACOUSTIC CAMERA

SEEING IS BELIEVING



Take a snapshot or shoot a video for instant sharing



Noise spectra with clear indication of overall sound power values

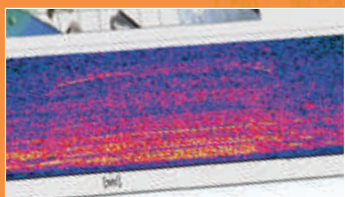

Spectrogram for clear visualization of structure in the noise



You might not believe how fast the latest addition to the PULSE Reflex™ family is to set up. The acoustic camera, offering all the well-known reliability and quality of Brüel & Kjær, is an easy-to-use, portable system for visualizing sound and detecting buzz, squeak and rattle in vehicles – and it takes less than four minutes to be up and running.

The compact size makes the camera highly suitable for confined spaces, allowing you to clearly view sound sources in vehicles. You can take both stationary and non-stationary measurements and troubleshoot problem areas, instantly sharing snapshots and analyzing recordings.



For more information or a quote please contact us.
webform@nichecom.co.nz Ph. 04 2323233

Brüel & Kjær 

BEYOND MEASURE

nichecom

Test Equipment Sales Calibration & Repair
www.nichecom.co.nz

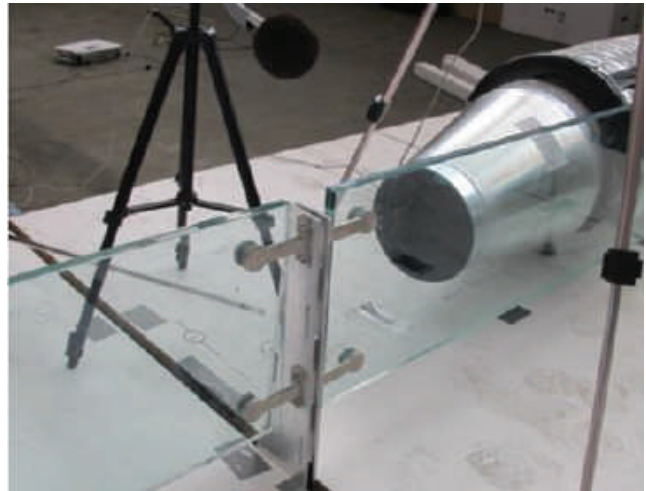
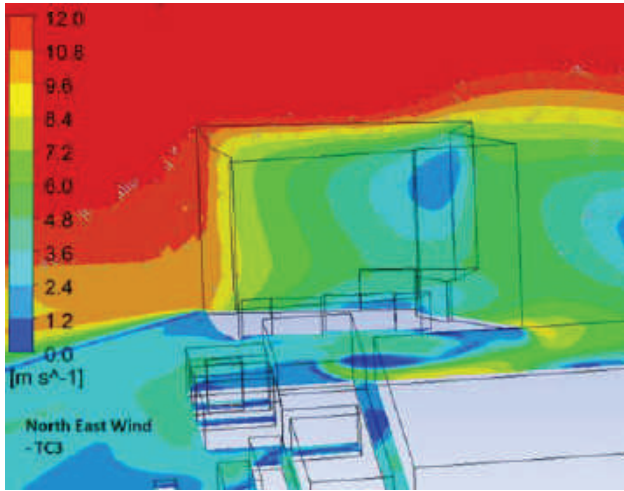

Figure 12: CFD model of AMNS to establish façade wind speeds (left) and test rig set up (right)

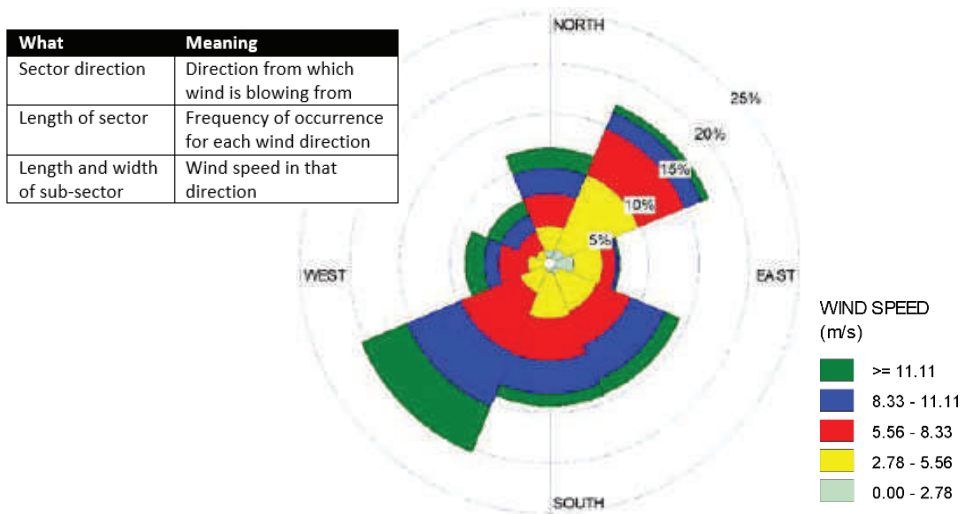

Figure 13: Wind rose of hourly observations recorded at the Adelaide Airport BoM station in 2014

Lease for funding the case study work, and Kingswood Aluminium for constructing the façade mock-up.

10. References

- Akagi, Y., Sato, K., Iwama, N. and Kubota, K. (1998) "Low-Noise Conductor for Harmonizing 1,000 kV Transmission Lines with the Environment", <http://jglobal.jst.go.jp/public/20090422/200902149361341126>
- Baker, K. (2015) www.dailymail.co.uk/news/article-3340989/Sky-scraper-makes-beastly-howl-time-wind-blows.html#ixzz48n2kwAgp
- Chanaud, R.C. (1970) "Aerodynamic Whistles", *Scientific American*, pp 40-46.
- Choi, C.K. and Kwon, D.K. (1998), "Wind tunnel effects on aerodynamic behaviour of bluff body", *Wind and Structures an International Journal*, Vol. 1, No. 4, pp. 351-64.
- Coppa, F. and Paduano, C. (2015) "Design Process to Evaluate Potential of Wind Noise at Façade Elements", *EuroNoise 2015*, Maastricht.
- De Jong, A.T. (2008) "Experimental and numerical investigation of the flow-induced resonance of slender deep cavities", Master of Science Thesis, Delft University of Technology.
- Fricke, H.W. (2010) "Criteria for Façade Element Testing", *AWES Workshop*, Perth.
- Leeming, C. (2006). "Tallest Tower Whistles in the Wind", *The Enquirer-North West*, Issue 2, 4-10 May.
- Lighthill, M.J. (1952, 1954), "On Sound Generated Aerodynamically. Part I: General Theory, II. Turbulence as a Source of Sound" *Proc. Roy. Soc. Lond.*, A211 & A222
- Massenzio, M., Blaise, A. and Lesueur, C. (2008) "Mechanisms of Self-Sustained Oscillations Induced by A flow Over a Cavity", *J. Vib. Acoust* 130(5).
- Mitchell, A., Leclercq, D., Stead, M. (2010). "Control of Aeolian Noise Generated by the Finned Balustrade of a Freeway Pedestrian Overpass", *noise notes*, Vol 9(4), pp. 35-48.
- Moloney, D., Peoples, D. and Mantophani, H. (2010) "Testing and Assessment of Wind Noise around Buildings", *AWES Workshop*, Canberra.
- Ploemen, J.C.F., Nijs, L., Pleysier, J.A. and Schipper, H.R. (2011) "Wind-Induced Sound on Buildings and Structures", *Proceedings of the 13th International Conference on Wind Engineering, ICWE 13*, Amsterdam, 10-15 July 2011
- Rofail, A.W. and Tonin, R. (2000) "An Exploration of Wind Noise in Buildings", *AWES Workshop*, Perth
- Ver, I.L. and Beranek, L.L. (2006) "Noise and Vibration Control Engineering – Principles and Applications", Chapter 15 – Noise of Gas Flows, 2nd Edn., Wiley.